



FR-COMPACTOR

FIRE RESISTANCE WITH SPACE OPTIMIZATION

KEY FEATURES

- FRRC cabinets are certified as per IS-14203 from the Bureau of Indian standards for both 60 and 120 minutes.
- Each cabinet comes with a strong bolt work mechanism controlled by 6 levers dual control key lock.
- Innovative drive mechanism for effortless movement.
- The anti-tilt mechanism ensures the stability of the base.
- A safety latch is provided to lock the drive unit during cabinet access.
- Superior quality guide rails to ensure smooth and swift movement.

PAN INDIA SERVICE AND INSTALLATION NETWORK

A **GUNNEBO**® BRAND

STEELAGE

FR-COMPACTOR

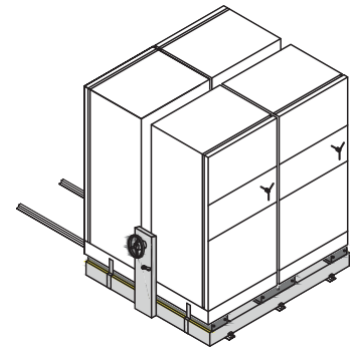
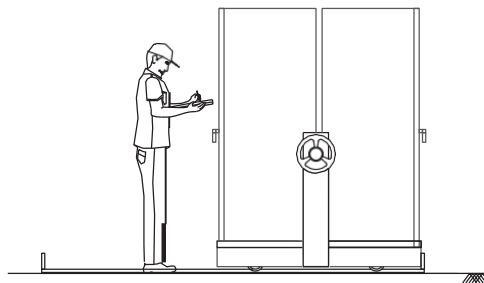
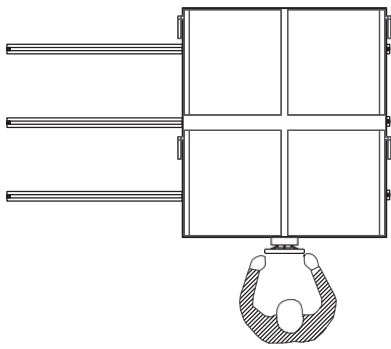

Fire Resistance



Strong bolt mechanism



Safety latch stopper



Anti-tilt mechanism



Quick & easy movement



Six lever dual control key lock

Authorised Steelage Partner



Svanz International Pvt. Ltd.
Punjab, Haryana, HP, J&K
Plot no. 990, Sector - 82, Mohali
For enquiry call us at: 9041690417, 9855100370
Or email at sales@svanz.com

www.Svanz.com

The data given in this material may be subject to change without prior notice. This document is not contractually binding. The Steelage brand is owned by Gunnebo AB. See www.steelage.com for more information.